

CHIPPEWA VALLEY ELECTRIC COOPERATIVE

Your Touchstone Energy® Cooperatives 

Load Management Programs

Saving More than Energy

Chippewa Valley Electric Cooperative

P.O. BOX 575, Cornell, WI 54732

(715) 239-6800 / Fax 239-6160

800-300-6800

www.cvecoop.com

Chippewa Valley Electric Cooperative

Dual Fuel & Load Management Wiring Guide

Table of Contents

Dual Fuel Program	3
Requirements	4
Expectations	4
History of Control Hours	4
Your Backup Heat Source	5
Wood as a Backup Heat Source	5
Responsibility	6
Air Conditioning and Heat Pumps	6
Additional Information.....	6
Basic Load Management Requirements.....	7
Member Responsibilities	7
Contractor Responsibilities.....	7
Installation Requirements.....	8
Loads Allowed in Off-Peak Load Center	9
<i>Load Management Programs</i>	10
Space Heating	10
Dual Fuel (Including heat pumps and hydronic in-floor heating):	10
Storage Space Heating.....	10
Water Heating	11
Storage Water Heating.....	11
Cycled Central Air Conditioning.....	12
Central Air Conditioning Only	12
Off-Peak Heating Rates	13
Dual Fuel Rebates.....	13
Fuel Cost Comparison	13
Chippewa Valley Electric Cooperative Rate History	14
CT Metering.....	15
Service of Load Management Receivers (LMR) and Off-Peak Panels	16
<i>Commercial, Industrial, & Agricultural</i>	17
General Program Description	17
Coincidental Demand Billing and Excess Demand Charge	17
Method of Interruption	17
Control Length and Days per Year.....	18
Interruptible / Gen-Sets	18
Interruptible Service Rates	18
Availability	18
Irrigation.....	18
Irrigation Service Rates.....	18
<i>Types of Electric Heat</i>	19
<i>Should I Attempt to Install Electric Heat Myself ?</i>	21
Typical Dual Fuel Meter Installation.....	23
Member Agreements.....	23

Dual Fuel Program

The Dual Fuel program is a program designed by electric cooperatives that allows Members to take advantage of lower cost electricity for home heating.

Whether you are building a new home or upgrading your current heating and/or air-conditioning systems (HVAC), we can help you reduce heating and cooling costs with our Dual Fuel Program.

To qualify for the Dual Fuel Program, your primary heat source must be electric, with a demand of at least 8KW. You must also have a back-up heating source which is *not* electric, such as an LP or Fuel Oil furnace, or a heat storage source such as a storage furnace or in-floor heat installed in a concrete slab. All electric heat must be controlled.

By entering into the Dual Fuel Program, you agree to allow Chippewa Valley Electric Cooperative (CVEC) to control your HVAC system(s) during periods of peak demand. It is at these times you will rely on your back-up heating system(s).

In return for allowing CVEC to interrupt your HVAC, you will receive a reduced rate for the electricity used for HVAC. The rate is currently 46% less than the normal rate for heating (Sept. through May) and 20% less for cooling (June through August).

CVEC will install a Load Management Receiver (LMR) on the Member installed meter socket for CT Meter installations, or as a stand-alone unit for Parallel (double pedestal) installations. The LMR is used to control the HVAC system(s). This is a device approximately 6" x 12". During periods of peak demand, a radio signal is sent to the LMR, which controls the load for a predetermined period of time.

Requirements

The Member's Contractor installs electric heat (boiler, plenum, heat pump, etc) in addition to another (back-up) heating source, such as fuel oil or propane (LP). The electric heat is connected to a separate meter and a control device (Load Management Receiver) so the electric heat can be controlled (turned off) during periods of high electricity demand. Please see Page 19 for suggested electric heat options.

In return for allowing the electric heat to be controlled during the times of peak demand, the Member receives a reduced rate for the electricity used for heating, in part because the electric cooperative is able to reduce their demand from their supplier (Dairyland Power), who in turn can avoid purchasing power off the Grid at a premium.

Expectations

With a properly designed and installed Dual Fuel System, the Member should not experience any discomfort during control periods.

It is nearly impossible to forecast how often and for what duration the Dual Fuel heat will be interrupted. It is primarily controlled on the very coldest winter days, and the program is designed so that the electric heat could be off indefinitely.

History of Control Hours

Heating Season	Control Hours
Winter 2009-2010	87.5
Winter 2008-2009	228.45
Winter 2007-2008	121.8
Winter 2006-2007	50.2
Winter 2005-2006	48.3
Winter 2004-2005	63.95
Winter 2003-2004	38.15
Winter 2002-2003	20
Winter 2001-2002	10
Winter 2000-2001	56
Winter 1999-2000	39.5
Winter 1998-1999	38.5
Winter 1997-1998	26.5

Your Backup Heat Source

It is imperative that you have fuel for your backup source of heat available, as the electric heat will be controlled during the coldest times of the winter. We strongly encourage Members to continue to have their secondary heating systems annually tuned-up and in proper operating condition.

Wood as a Backup Heat Source

The Cooperative will allow wood as a backup heat source; however, an automatic backup system is recommended. If the house is unoccupied during a control period, and the backup system is not automatic (LP or fuel oil furnace), the house could freeze up.

Responsibility

Regardless of the source of backup heat, the Member accepts all responsibility that the Dual Fuel System is working properly to avoid potential freeze up during a control period.

Air Conditioning and Heat Pumps

Central Air Conditioning and/or a Heat Pump is/are allowed on the Dual Fuel program, provided it is controlled by the LMR.

Air conditioning is controlled during the summer peak periods, and the electricity used by the air conditioning is delivered at a reduced rate for the months of June, July, and August.

Some Heat Pumps can only be reliably controlled by interrupting line voltage. Please consult with your HVAC contractor regarding controlling of your Heat Pump to be eligible Dual Fuel Program. It is the Member's responsibility to obtain information from the HVAC contractor regarding controlling of a Heat Pump, and relay this information to Chippewa Valley Electric Cooperative.

If you are considering controlling line voltage it is imperative that you verify there is *not* a crankcase heater on the compressor. If a compressor is fitted with a crankcase heater, a dedicated 2- conductor 18 gauge (minimum) wire (typically thermostat wire) must be run from the compressor to the LMR (by way of the Main Load Center).

To control line voltage a 2-pole contactor with a 120VAC coil is required. The contactor must be rated for the circuit being controlled. CVEC stocks a 2-Pole 30A contactor.

Additional Information

More information on Chippewa Valley Electric Cooperative's Dual Fuel program, as well as real-time status of load management events can be found on the Web at www.cvecoop.com . You may also e-mail your questions to Member Services. Contact Nicole (nwsime@cvecoop.com) or Russ (russ@cvecoop.com) or call Chippewa Valley Electric at 800.300.6800.

Basic Load Management Requirements

Please contact CVEC Member Services to make certain that the proposed system(s) meet requirements. See Load Management Programs (Page 10) for the basic requirements.

Member Responsibilities

- 1) Complete, Sign and return a Dual Fuel Agreement (Page 24)
 - a. Select a qualified contractor and check references.
- 2) Arrange for installation
- 3) After installation is complete and tested by Contractor, contact CVEC Member Services to schedule installation of Load Management Receiver (LMR) and Dual Fuel Meter.

Contractor Responsibilities

- 1) Verify electrical system capacity will not be exceeded with addition of Dual Fuel.
- 2) Install HVAC system(s) to be controlled.
- 3) Install Dual Fuel meter socket and/or Load Center in accordance with CVEC wiring diagram(s).
- 4) Install control wiring (typically 14/2NM) between load(s) and Main Load Center.
 - a. If this installation includes a Heat Pump, CVEC must know in advance. If line voltage is controlled, contractor is to install 2-Pole contactor IAW CVEC wiring diagrams.
 - b. If this installation includes a Plenum Heater contractor is responsible for all low voltage (i.e. thermostat and A/C Compressor) wiring. Contractor is also responsible for performing temperature measurements per manufacturer's instructions and submitting any warranty documents.
- 5) All wiring must meet minimum current National Electric Code requirements.
- 6) Submit completed Wiring Affidavit to CVEC. (See Page 32)

Installation Requirements

- 1) Off-Peak metering may be subtractive or dual (parallel/double pedestal) metering.
- 2) Subtractive metering and LMR will be outside of the home or other building, and be mounted at a height of 5 feet above finished grade. (i.e. at eye level).
- 3) For new services, a Double Pedestal (dual metering) is required if the anticipated HVAC load is greater 13KW.
- 4) Water Heaters are connected to the main electrical panel. Water Heaters are not eligible for the Dual Fuel Rate, but instead receive a \$3.00/month credit, provided a minimum of 500KW is used in said month.

Loads Allowed in Off-Peak Load Center

A Load Center that is designated as Off-Peak or Dual Fuel shall contain *only* the following loads –

- Electric Heat
 - Boiler
 - Electric Thermal Storage
 - Baseboard or Cove Heat
 - Plenum Heater
 - Heat Pump (Compressor only)
- Air Conditioning (Compressor only)

Per the Dual Fuel Agreement, all electric heat must be controlled.

All other loads, including Water Heaters, clothes dryers, circulator pumps, and blower motors must be connected to the Main Load Center.

Off-Peak or Dual Fuel Load Centers will bare label appearing below, and also be locked and tagged. If you must enter the Off-Peak or Dual Fuel Load Center, please contact CVEC first.

IMPORTANT

READ BEFORE SERVICING THIS PANEL

ONLY ELECTRIC HEAT, CENTRAL AIR CONDITIONING and equipment authorized by this cooperative are allowed in this panel.

ALL ELECTRIC HEAT IN THE BUILDING MUST BE CONNECTED TO THE DUAL FUEL PROGRAM AND MUST BE CONTROLLABLE. THE USE OF UNCONTROLLED ELECTRIC HEAT MAY RESULT IN DISQUALIFICATION FROM THE PROGRAM AND ANY ENERGY USED SINCE THE LAST INSPECTION MAY BE BILLED AT AT THE GENERAL PURPOSE RATE.

Before servicing, insure that the proper circuits have been disconnected. **POWER TO DEVICES CONTROLLED BY THIS SYSTEM MAY BE SWITCHED ON AUTOMATICALLY.** If power is interrupted the load management equipment may not operate for seven minutes after power restoration.

THIS PANEL IS SEALED WITH COOPERATIVE SEALS. TAMPERING OR REMOVAL OF SEALS WITHOUT PERMISSION MAY RESULT IN DISQUALIFICATION FROM THE DUAL FUEL PROGRAM AND ENERGY USED SINCE THE LAST INSPECTION MAY BE BILLED AT THE GENERAL PURPOSE RATE.

Contact Chippewa Valley Electric Cooperative at 715.239.6800 or 1.800.300.6800 for more information or to obtain permission to break the load management seals.

CV-14

Load Management Programs

Space Heating

Dual Fuel (Including heat pumps and hydronic in-floor heating):

Dual Fuel means what the term implies; two fuels, electric for primary heat source, and a fossil fuel for backup. A backup system is required to participate in the Dual Fuel Program.

Properly designed, you should not notice a difference in temperature when your electric heat is controlled.

Hydronic in-floor heating, installed in a concrete slab (i.e. a basement floor) does not require a backup source, as the heat stored in the concrete acts as a backup source.

A Dual Fuel system may be controlled up to 12 hours in any 24 hour period during the heating season. If load control is necessary, the *typical* control period is between 5PM and 10PM. Heat pumps and Central A/C units will be cycle-controlled in the summer. Typical control periods in the summer run about 6 hours, and the cycle time is 15 minutes on and 15 minutes off. Only the compressor is cycled, the blower is not interrupted by the load management system.

Storage Space Heating

Electric storage furnaces and storage room heaters are options that allow members who heat with electricity to avoid a fossil fuel backup heating system.

All electric heat in a home must be controlled.

Storage space heating equipment is heated (or charged) between the hours of 9:30PM and 5:30AM. A 2 hour "booster charge" may be possible in the afternoon for systems meeting certain requirements.

CVEC maintains a close working relationship with Steffes Corporation, a leading manufacturer of Storage Space heating units, and Central Storage Furnaces. CVEC will work with you (the Member) to arrange ordering and delivery of Steffes Central Storage Furnaces, provided the furnace is installed by a contractor who has been trained and certified by Steffes Corporation. You must provide the name of the contractor before an order will be placed.

Water Heating

Storage Water Heating

Water heating is one of the most costly energy requirements in your home. Chippewa Valley sells water heaters to our monthly residential members at a special low cost. Water Heaters are not part of the Dual Fuel Program (no reduced electric rate), however a \$3/month credit is given, provided at least 500KW of electricity is used during said month, for participating in the Water Heater Load Management Program. The Water Heater must be under Load Management Control to qualify for this offer.

PURCHASE PROGRAM

How the Purchase Program works:

Sales tax is paid when the heater is picked up from our Cooperative offices.

- Water heater is billed to the electric account at \$10/month until it is paid off, no interest or service fee charged
- Member is responsible for heater installation
- CVEC's staff electrician will install the load management control
 - LMR must be installed within 2 weeks of purchase
- Member will receive \$3/month credit for the load control (*account has to use at least 500kwh/month to qualify for credit*)

50 Gallon Rheem	\$ With Load Control	\$ Without Load Control
	\$260.00 plus sales tax	\$380.00 plus sales tax
19 inch diameter / 58 inches high / 121 lbs. / 6 year warranty on tank (residential) 240 Volt / 30 amp / 2-4500 watt elements* / glass lined steel tank / R-foam Insulation		
80 Gallon Rheem	\$ With Load Control	\$ Without Load Control
	\$520.00 plus sales tax	\$720.00 plus sales tax
23 inch diameter / 59 inches high / 182 lbs. / 6 year warranty on tank (residential) / 240 Volt / 30 amp / 2-4500 watt elements* / glass lined steel tank / R-foam Insulation		
85 Gallon Marathon	\$ With Load Control	\$ Without Load Control
	\$600.00 plus sales tax	\$995.00 plus sales tax
28 1/4 inch diameter / 70 1/4 inches high / 124 lbs. / Lifetime warranty on tank (residential) / 240 Volt / 30 amp / 2-4500 watt elements* / Non-metallic tank / R-foam Insulation		

* CVEC will warranty elements & thermostats for the life of water heater-parts only.

Cycled Central Air Conditioning

CVEC offers a reduced rate for central Air Conditioning, for Members participating in the Dual Fuel Program.

Central Air Conditioning Only

Starting in 2007, CVEC offers an incentive for Air Conditioning only loads.

Members are eligible for a \$6/month credit during the months of June, July, and August. To take advantage of this program a completed Interruptible Service - Air Conditioner agreement must be submitted to CVEC. (See Page 31). A LMR is then installed on the A/C Compressor by CVEC.

Installations must be completed by the 20th of the month to receive credit for that month.

Chippewa Valley Electric Cooperative

Dual Fuel & Load Management Wiring Guide

Off-Peak Heating Rates

A \$4.00 monthly facility charge is applied to all Dual Fuel meters. Please refer to the CVEC web site (www.cvecoop.com) for current rates.

Dual Fuel Rebates

A \$250 rebate is paid to the Member upon completion of a Dual Fuel System installation in accordance with CVEC guidelines. Please be sure to obtain the most current copies of wiring diagrams before starting the project. Rebates will not be issued if the system installation is not complete, or not wired in accordance with CVEC guidelines when CVEC arrives to install the Dual Fuel Meter and LMR.

Please see the Dual Fuel Agreement, Page 24.

Fuel Cost Comparison

	Electricity (\$/kWh)	Propane (\$/Gal.)	Propane (\$/Gal.)	Propane (\$/Gal.)	Fuel Oil (\$/Gal.)	Fuel Oil (\$/Gal.)
BTU/Unit	3,413	91,333	91,333	91,333	138,690	138,690
Efficiency	100%	70%	80%	90%	60%	70%
	\$0.050	\$0.937	\$1.070	\$1.204	\$1.219	\$1.422
	\$0.053	\$0.993	\$1.135	\$1.276	\$1.292	\$1.508
	\$0.059	\$1.105	\$1.263	\$1.421	\$1.439	\$1.678
	\$0.060	\$1.124	\$1.284	\$1.445	\$1.463	\$1.707
	\$0.065	\$1.218	\$1.392	\$1.565	\$1.585	\$1.849
	\$0.068	\$1.264	\$1.445	\$1.626	\$1.646	\$1.920
	\$0.070	\$1.311	\$1.499	\$1.686	\$1.707	\$1.991
	\$0.073	\$1.367	\$1.563	\$1.758	\$1.780	\$2.076
	\$0.079	\$1.480	\$1.691	\$1.903	\$1.926	\$2.247
	\$0.080	\$1.499	\$1.713	\$1.927	\$1.951	\$2.276
	\$0.085	\$1.592	\$1.820	\$2.047	\$2.072	\$2.418
	\$0.088	\$1.648	\$1.884	\$2.119	\$2.146	\$2.503
	\$0.090	\$1.686	\$1.927	\$2.168	\$2.194	\$2.560
	\$0.093	\$1.742	\$1.991	\$2.240	\$2.267	\$2.645

This chart is based on information obtained from the USDA (<http://www.fpl.fs.fed.us/documnts/techline/fuel-value-calculator.pdf>)

Chippewa Valley Electric Cooperative

Dual Fuel & Load Management Wiring Guide

Chippewa Valley Electric Cooperative Rate History

	Heating	Cooling
	(per Kwh)	
1981	3.0 cents	
1982	3.8 cents	
1984	3.4 cents	4.6 cents
1987	3.7 cents	5.0 cents
1993	3.2 cents	4.5 cents
1994	3.4 cents	4.5 cents
2001	3.5 cents	4.6 cents
2004	3.7 cents	4.9 cents
2005	4.4 cents	5.6 cents
2006	5.0 cents	7.5 cents
2009	5.9 cents	8.4 cents
2010	5.9 cents	8.6 cents
2011	6.1 cents	8.6 cents

CT Metering

If sub-metering is used at the house, CT metering is usually the simplest and most cost effective method to meter off peak loads.

A Milbank S1994-WL-KK meter socket, 200:5 ratio CT, 1" Hub, and 1" x 3/4" bushing are available from CVEC as a package for approximately \$75 (price subject to change without notice).

It is the responsibility of the Member, or Member's contractor to install the meter socket, CT, and control wiring for the Dual Fuel system. The system must be installed in accordance with the National Electric Code, applicable local electrical codes, and most current diagram supplied by CVEC.

One leg (phase) from each circuit to be CT metered must pass through the CT twice. All circuits run through the CT must be the same phase, and pass through in the same direction. The current flow must be from the circuit breaker to the "source side" of the CT. The red wire from the "5th pin" of the meter socket must be connect to the same phase as the loads passing through the CT.

Control wiring (typically 14/2NM) must be run from each load to be controlled to the Main Load Center. CVEC is responsible for connecting control wiring through to the LMR.

The power source (240VAC) for the meter socket and LMR must be a dedicated 2-pole, 15A circuit breaker. A loss of power to the meter would move the electric heat usage to the general service rate.

CT Submeters must be powered on at all times. If a CT Submeter is powered off, it will be removed from the Dual Fuel Program.

Accuracy and burden becomes primarily a function of installation and wire resistance between the CT itself and the meter. It is imperative the following criteria be met when installing a CT Submeter:

- Standard wire (THHN, TFFN, etc) is preferred
- Make sure the stripped wire is clean and properly prepared for a firm copper-to-copper connection
- If using wire nuts at the CT pigtails (stranded wire only), twist the strands first prior to twisting on the wire nut
- If solid conductor wire is used, only a screw clamp terminal (not wire nut) shall be used for joining the solid conductor to the stranded CT pigtails. Buchannan Crimp Sleeves are also acceptable

Chippewa Valley Electric Cooperative

Dual Fuel & Load Management Wiring Guide

The following wire gauge must be used:

<u>Length of Wire Run</u>	<u>Size</u>
10ft	# 14
16ft	# 12
23ft	# 10

- If you cannot use the wire gauge specified above or if the length is longer than shown, consult the CVEC metering department for another specified component.

Service of Load Management Receivers (LMR) and Off-Peak Panels

CVEC provides and maintains the LMR. The contacts are normally closed so in the event of a failed LMR, the off-peak load is unable to be controlled. If a member has no heat or hot water and it is not due to planned load control, it is likely there is a problem with Member-owned equipment. Members are advised to call their own serviceperson to find the source of the problem. If CVEC can verify that the problem was due to the LMR, CVEC will reimburse Member for the service call, provided the charges are reasonable and customary.

Peak Interrupter Panels and Off-Peak Load Centers are the Member's responsibility. CVEC seals that may be on the panels can be removed for service, after notifying and obtaining permission from CVEC. Contact CVEC to reseal the panel(s).

If a serviceperson is called out after hours and has to disable a LMR in order to fix a problem, please call CVEC as soon as possible to notify that the LMR is disabled. A qualified electrician familiar with CVEC's Load Management Receivers will have the knowledge to disable a LMR.

Commercial, Industrial, & Agricultural

General Program Description

The customer will be alerted to potential peak periods one-half hour in advance of the potential peak period. CVEC has the right to vary the times and lengths of interruptions within the hourly daily limit(s).

Power during the interruption periods will be supplied by the Member's standby generator. The Member will have the choice of either an automatic system or manual start and transfer type equipment.

In return for allowing the above interruption of service, the Cooperative will apply the monthly rate to all electricity purchased by the member at the applicable account.

Coincidental Demand Billing and Excess Demand Charge

These are important factors to consider. Please Contact CVEC Line Superintendent for details.

Method of Interruption

The method of interruption will vary slightly, depending on whether the system is automatic or manual.

A LMR will be installed by CVEC adjacent to the electric meter. The LMR remains the property of CVEC and CVEC will be responsible for maintenance of the device. It would, however be in the best interest of the member, to notify CVEC of any possible problems with the device.

The LMR will be capable of an early warning, about 30 minutes in advance of the control time. No penalty would occur unless the load is not transferred within the ½ hour warning. The Member is responsible for connecting an approved warning signal that will adequately notify of a control period. The electric meter will also record the peak alert signal and verify it by date and time stamping.

With a totally automatic gen-set system, the LMR is simply connected to the warning device. The Member will be responsible for having the generator running and the load switched by the designated control time and also for restoring the load at the completion of the control period.

CVEC will provide, maintain, and read all metering equipment needed to provide this service.

Control Length and Days per Year

It is not possible to project the number of days per year that the control will occur, as weather has a significant impact on the need for load management. Typical controls occur during extreme weather conditions.

Interruptible / Gen-Sets

In an effort to reduce peak demand and provide a fair and competitive electric rate to our members, CVEC offers the following Interruptible service.

Under the interruptible load program, an entire load is either transferred to a backup generator or turned off. CVEC will install special metering and a LMR that is capable of starting the generator and transferring the load to the generator. A qualified, licensed electrician is responsible for wiring beyond the LMR. The Member is required to contact CVEC for program specifics.

Interruptible Service Rates

Contact CVEC Line Superintendent for details

Availability

Available for all uses accepted by the Cooperative on an experimental basis and where the required transformer capacity is equal or greater than 150KVA. All subject to the established rules and regulations of the Cooperative and execution of a Electric Service Agreement between the Cooperative and the Member.

Irrigation

Center pivot irrigation systems that are controlled during the summer peaks receive a reduction in demand charges. At present, if controlling is necessary, CVEC's irrigators are limited to being controlled for a maximum of 4 hours, ending by 8PM. There will be only one control period per day, typically in the evening.

Irrigation Service Rates

Contact CVEC Line Superintendent for details

Types of Electric Heat

Plenum Heater

If plenum sizing and the capacity of the electrical service are adequate, an electric plenum heater is the most cost effective method of adding electric heat to an existing fossil fuel forced air furnace.

Additional information is available from Electro Industries, Inc. at <http://electromn.com/res/html/em.htm> .



Electric Boiler



Electric Boilers are an ideal solution for in-floor heating applications. When used with in-floor heating applications in a concrete slab, Electric Boilers can be used as a “stand-alone” Dual Fuel system, as the heat stored in the concrete slab can be use as a back-up heat source during control periods.

More information is available at <http://electromn.com/res/html/em.htm>

Cove Heat



Cove Heat is a new approach to conventional baseboard heaters. Cove heaters are mounted on the wall, 8' above the floor. The heat is projected down, warming the air and objects in the room. Natural convection moves air through the heater. Cove heaters are an excellent compliment to Storage Space Heating.

More information is available at www.radiantsystemsinc.com .

Storage Space Heating

Room Unit

Room Heating Units (2100 Series Fan Forced)



Room units are non-ducted heaters which are designed to heat the room or area into which they are placed. These heaters can be used in new construction applications or as a retrofit or supplement to an existing heating system. Various sizes of room units are available ranging from 1.32kW, 120V - plug-in units to larger 10kW, 240V models. The "Fan Forced" 2100 series units have the ability to quickly discharge vast

amounts of heat as desired.

During off-peak hours, ETS heaters convert electricity into heat and store that heat in specially designed high-density ceramic bricks. These bricks are capable of storing vast amounts of heat for extended periods of time. This stored heat is circulated evenly and quietly by a fan inside the unit as the room thermostat calls for heat. The ETS equipment is easy to operate and requires very little maintenance. The amount of heat stored in the brick core of the heater is regulated (either manually or automatically) according to seasonal weather conditions. The on-board room temperature thermostat is set to your desired comfort level and will control the delivery of heat from the ETS heater.



Central Storage Furnace

Comfort Plus Forced Air Heating System



The Comfort Plus unit is designed to be the main heating system (forced air) for residential or small commercial applications. The Comfort Plus unit can be used as a stand alone furnace or can be installed with a heat pump to realize even greater efficiency and energy savings. It is a versatile appliance that can serve as a back-up for an electric furnace during on-peak times, replace a duct heater, or supplement a fossil fuel system. During of-peak hours, the Comfort Plus unit converts electricity into heat and stores that heat in specially designed, high density ceramic bricks. The Comfort Plus system has the heat storage capacity to provide total comfort 24 hours a day, while allowing the user to utilize low cost off-peak electric rates to achieve very economical and affordable heating.

The Comfort Plus unit is easy to operate. The amount of heat stored in the brick core is automatically regulated in relation to outdoor temperature and the heating requirements of the user. When the room thermostat calls for heat, heat is extracted from the unit's storage core and is distributed evenly into the home until the heat call has been satisfied.

More information is available at www.steffes.com

Should I Attempt to Install Electric Heat Myself ?

Chippewa Valley Electric Cooperative (CVEC) strongly encourages you to engage the services of an experienced, knowledgeable electrical contractor for all electrical projects.

While it may be possible to save some money by installing electric heat such as a plenum heater or boiler yourself, it is imperative you understand the electrical requirements. If you do not fully understand what is required for a safe and successful installation, and why, it is to your advantage to enlist the services of a qualified electrician.

If you answer "*No*" to *any* of the following questions, we strongly recommend that you do NOT attempt the installation without the services of a qualified electrical contractor.

- Do I know what the increased load will be?
- Do I know if my existing electrical service will safely handle the increased load?
- Will my electrical service require an upgrade (i.e. upgrade from 100A to 200A)?
- Do I know what size wire is required, and how to properly route, mark, and terminate it?
- Am I comfortable working inside an electrical panel?
- Do I understand what a "phase" is?
- Do I understand how to correctly install a Current Transformer (CT), a CT Meter Socket, and conduit per the drawings provided by (CVEC)?
- Do I have the proper tools required for this project?
 - o For Electro Plenum Heaters: WarmFlo Analyzer is required!
- Am I sure my installation will meet all applicable National Electric Code (NEC) requirements?
- Am I willing to sign the required wiring affidavit? (See Page 32)
- Am I willing to forfeit the Dual Fuel Rebate (\$ 250) and reschedule the installation if I do not meet CVEC and NEC requirements?

If you answered "*No*" to any one of the above questions, please contact a qualified electrical contractor.

CVEC will ***not*** install a meter if –

- There are safety concerns
- Wiring is not in accordance with CVEC provided diagrams
- There are obvious NEC violations

Heat Loss Calculations

(Rule of Thumb shortcut Methods)

◆ **Cubic Foot Method for Calculating Heat Loss:**

- ⇒ Homes with a basement: Use 2.75 BTU heat loss/cubic foot for the upper level and 1.75 BTU heat loss/cubic foot for the basement.
- ⇒ Homes on slab or crawlspace: Use 3.1 BTU heat loss/cubic foot for all areas.

Example: Assume a 1000 square foot main level home plus 1000 square foot basement with 8' ceilings
Upper Level Heat Loss = $1000 \times 8 \times 2.75 = 22,000$ BTU
Lower Level Heat Loss = $1000 \times 8 \times 1.75 = 14,000$ BTU
Total Estimated Heat Loss is 36,000 BTU or 10.55 kW
(3412 BTU = 1kW).

◆ **Cubic Foot Method for Calculating Heat Gain (for cooling needs):**

- ⇒ Use 2 BTU heat gain/cubic foot for all areas except those below grade. (Ignore the basement.)
- ⇒ To size a cooling system, figure about 12,000 BTU/ton

Example: Assume 1000 square foot main level with 8' ceilings
Heat Gain: $1000 \times 8 \times 2 = 16,000$ BTU
Cooling System Size: $16,000/12,000 = 1.3$ tons
(12,000 BTU's = 1 ton)

◆ **Square Foot Method:**

Assuming 7 to 8 foot high ceilings, use 6.5 watts heat loss/square foot on the upper level and 4 watts heat loss/square foot on the lower level.

The above short cuts assume an average quality built home which has insulation values of approximately R-19 walls, R-38 ceilings, good windows and doors, etc. You can adjust the rule of thumb numbers up or down if quality of construction is better or worse.

Reminder: Short cuts or rules of thumb have been successfully used for many years. In many situations, they will serve you very well and will save you a lot of time. To arrive at the most accurate heat loss or heat gain figures, a full blown heat loss calculation is suggested.

Typical Dual Fuel Meter Installation



Member Agreements
and important drawings appear on following pages

**Chippewa Valley Electric Cooperative
Member Agreement**

Interruptible Service – Dual Fuel

This agreement made and executed this ____day of _____, 20____
by and between Chippewa Valley Electric Cooperative, headquartered in Cornell,
Wisconsin (hereinafter referred to as the "Cooperative"), and _____
_____ (hereinafter referred to as the "member").

WHEREAS, It is in the joint interest and benefit of the named parties to conserve
the use of electrical energy and minimize the cost of electrical energy sold and
delivered by the Cooperative to the Member; and

WHEREAS, This can be accomplished by the Cooperative disconnecting certain
electrical loads during certain times; and

WHEREAS, The Cooperative has made such service available to qualifying
members.

NOW, THEREFORE, It is agreed by and between the parties as follows:

1. The Member, or Member's Contractor shall provide and install all
equipment and wiring, except control device and meter, in accordance with
Cooperative specifications as detailed in Load Management Programs (Basic Load
Management Requirements), as applicable, and subject to Cooperative approval
to qualify for an interruptible rate.

Initial: _____

2. It shall be the Member's responsibility to Contact the Cooperative's
Member Services Department to schedule installation of the meter and control
device after all equipment and wiring have been installed.

a. If, upon arrival at scheduled installation, The Cooperative determines
work has not been completed as outlined in (1), above, Member shall forfeit Dual
Fuel rebate and installation will be rescheduled for a later date.

Initial: _____

3. The Cooperative shall furnish and install control device and meter, which shall
remain the property of the Cooperative. Member shall permit the Cooperative
and its agents and employees to enter upon premises for purpose of
installing, maintaining, relocating, repairing, replacing, and removing said
devices and appurtenances thereto.

4. The Cooperative shall have authority to interrupt service taken under the
selected Interruptible Rate Schedule, recognizing that the Cooperative may
modify the terms and conditions of the selected Interruptible Rate Schedule
from time to time as required by its load characteristics.

Chippewa Valley Electric Cooperative

Dual Fuel & Load Management Wiring Guide

5. The Member shall not use electric energy for similar interruptible loads in an uncontrolled manner. If the Cooperative determines or suspects that electric energy usage has not been consistent with this Agreement, Interruptible Rate Schedule, service rules, or specifications, all control devices and meters may be removed and all electric service billed under the general rate schedule.
6. The Cooperative shall not be liable for any economic loss or personal discomfort due to the operation of the control device or the period of the service interruption. The Cooperative shall not be liable for any losses where wood is used as back-up.
7. Problems occurring with controlled loads shall be analyzed and corrected by member's electrician, and the Cooperative will reimburse the homeowner or electrician for reasonable costs, only if the problem was with the control device. Member shall immediately notify the Cooperative if the control device is not functioning.
8. If the control device is removed by the Cooperative and the Interruptible Rate discontinued for any reason, twelve (12) months shall elapse before the control device and Interruptible Rate can be used by the Member again.
9. This Agreement shall be in effect upon the date it was executed for a minimum period of five (5) years. Member shall have a right to terminate Agreement at any time after one year from date of this contract for any reason.
10. Member represents that he is the owner of the premises upon which said device is installed or if not the owner, the owner authorizes said installation as indicated below.
11. This Agreement shall be binding upon and inure to the benefit of the successors, legal representatives and assigns of the respective parties.

By: Chippewa Valley Electric Cooperative By: _____
(Cooperative) (Owner Signature)

(Address) (Account Number)

(Telephone Number)

Type of dual fuel system: Electric _____ kw _____
(Plenum, Boiler, Heat Pump, etc)

Type of back-up heating: _____

Central Air Conditioning controlled: Yes ___ No ___ kw _____

Last revised: 19 August 2009

File Name: U:\Member Services\Dual Fuel\DEA P1.docx

Sign & Return

Dual Fuel Meter Installation Contractor Responsibilities

Contractor/Installer hereby understands and agrees to the following requirements –

It is the Contractor/Installer's responsibility to have the following provisions made prior to contacting Chippewa Valley Electric Cooperative (CVEC) for installing of Dual Fuel meter and Load Management Receiver. Failure to comply with said requirements will result in forfeiting of \$ 250 Dual Fuel Rebate.

CT Sub-meter

- 1) Milbank S1994 Meter Socket shall be mounted on outside of building, at 60" above finished grade. ¾" (minimum size) conduit shall run continuously between Load Center and S1994 Meter Socket.
- 2) Chippewa Valley Electric Cooperative will provide the CT, at no cost to Member.
- 3) Member shall supply dedicated 2-Pole, 15Amp Circuit Breaker
- 4) Install wires in conduit per drawing (see *Load Management Programs* book). Wires shall be type THHN, rated f/ 600V
 - a. 1ea #10 Black
 - b. 1ea #10 Red
 - c. 1ea #14 Black
 - d. 1ea #14 Red
 - e. 1ea #10 Green
 - f. 2ea #16 Red
 - g. 2ea #16 Blue
 - h. 2ea #16 Yellow
 - i. 1ea #12 White
 - j. 1ea #12 Blue
- 5) Leave 12"-14" tails on all leads
- 6) Run wire(s) from Load Center to all controlled loads (Boiler, Plenum Heater, Furnace fan center, Water Heater, etc). Wire must be THHN, (rated f/ 600V), in conduit, and/or type NM. Clearly label all wires.
- 7) When all wiring requirements are met, please return this form, signed by the installer, along with the Wiring Affidavit. Receipt of these documents will alert CVEC that you are ready for us to install the Dual Fuel meter and Load Management Receiver.

Chippewa Valley Electric Cooperative

Dual Fuel & Load Management Wiring Guide

Parallel Meter (Double Pedestal Installations)

- 1) 3/4" PVC Conduit shall run continuously from Main Load Center to outside of building, w/ male terminal adapter & lock ring at 55" above finish grade.
 - a. Conduit must be left w/ open end facing up, or horizontal.
- 2) Install wires in conduit per drawing (See *Load Management Programs* book). Wires shall be type THHN, rated f/ 600V
 - a. 1ea #10 Black
 - b. 1ea #10 Red
 - c. 1ea #14 Black
 - d. 1ea #14 White
 - e. 2ea #16 Red
 - f. 2ea #16 Blue
 - g. 2ea #16 Yellow
- 3) Leave 12"-14" tails on all leads
- 4) Run wire(s) from Load Center to controlled loads (Boiler, Plenum Heater, Furnace fan center, Water Heater, etc). Wire must be THHN, (rated f/ 600V), in conduit, and/or type NM. Clearly label all wires.
- 5) When all wiring requirements are met, please return this form, signed by the installer. Receipt of this document will alert CVEC that you are ready for us to install the Dual Fuel meter and Load Management Receiver.



I have read and understand the wiring requirements as detailed in the *Load Management Programs* book, and this document.

Installer/Electrician Signature

Name (printed)

Date

Member Name

Account # (Found on Main meter)

Chippewa Valley Electric Cooperative Member Agreement Electric Water Heater Purchase Agreement

This Agreement made and executed _____, by and between the Chippewa Valley Electric Cooperative, headquartered in Cornell, Wisconsin (hereafter referred to as the 'Cooperative') and _____ (hereafter referred to as the 'member' or 'participant').

It is agreed by and between the parties as follows: Said member is the purchaser of an electric water heater from the Cooperative. Member agrees and understands that member must meet and continue to meet all eligibility and participation requirements. The Cooperative reserves the right to inspect the location and to review the account at any time to determine continued program eligibility of the member.

Program Eligibility Requirements:

- The participant must be a member of the Chippewa Valley Electric Cooperative being served under a monthly billed residential rate.
- Balance due amounts on this account shall be on a current basis.
- The participant may or may not currently be under the Cooperative's Load Management program, but must agree to begin.
- The participant must be purchasing a 50 gallon, or larger, electric water heater to be used for domestic hot water heating or for hot water heating in a milk house or milk parlor.
- The purchase of the water heater must be made from the Chippewa Valley Electric Cooperative.
- A member may purchase more than one (1) water heater, if each unit is under controlled service and if all other criteria for the incentive program are met.
- The participant's electrical energy consumption can be no less than **500 KWH** per month.
- The water heater must be installed and energized at a location on the electrical distribution system of the Cooperative no later than **two weeks** after being picked up at the Cooperative office.

Participation Requirements:

- The member must sign a purchase agreement for the water.
- The water heater will be paid by a \$10.00 a month direct charge to the member's electric bill.
- The member must continue to meet all program eligibility and participation requirements of the water heater program and of the load control equipment at all times during the repayment period identified under Participation Requirements
 - If the member fails to meet all the requirements during this time period said member shall be billed for and become liable for the entire cost of the heater.
- The member will agree to pick-up, install and maintain the water heater.
- The Cooperative will warranty water heater thermostats and elements for the life of the water heater, parts only. The Cooperative will not warranty the water heater (other than thermostats and elements) beyond the warranty period provided by the manufacturer.

Chippewa Valley Electric Cooperative

Dual Fuel & Load Management Wiring Guide

- The Cooperative will install and maintain the water heater control equipment, which shall be wired outside of the structure at a location designated by the Cooperative.
- If a member is renting or leasing housing where the water heater will be installed, the owner of the housing unit will be required to sign the purchase and control agreements. Payment shall become due in full should the rental property cease to be occupied and eligible for the credit.
- The Cooperative reserves the right to refuse sale or control of a water heater if it is not determined to be feasible from the standpoint of ability to control the heater or noncompliance with adopted criteria.
- The member will be responsible for obtaining qualified service for the water heater should it not operate properly. The Cooperative will reimburse the member for reasonable charges should the failure be in the control equipment.
- The water heater sale incentive program will not preclude or supersede any other marketing programs being implemented by the Cooperative.
- The Cooperative reserves the right to discontinue the water heater sale incentive program at any time except that all approved agreements will be honored.

SIGNED: _____ DATE: _____
ACCOUNT#: _____ MEMBER#: _____ Wtr Htr Size: ____ SERIAL #: _____
COST: \$ _____ TAX: \$ _____ TOTAL:\$ _____ Heater Location: _____
REPLACEMENT: Y N TYPE REPLACED: _____ Currently Controlled?: Y N

RECEIPT OF ELECTRIC WATER HEATER

1. I understand the warranty limitation when using this residential water heater in a non-residential application, and I further understand the warranty is void when the heater is operated at water temperatures exceeding maximum setting. _____
2. Water heater must be installed and energized within two (2) weeks _____
3. Water heater must be installed in a permanent structure residence _____
4. Water heater must be connected to load control for 50 months (min) _____
5. Must make arrangements for Co-op technician to have access to water heater during regular business hours to install receiver device, within two (2) weeks or I will be invoiced for the full cost of water heater. _____

Sign & Return

Chippewa Valley Electric Cooperative

Dual Fuel & Load Management Wiring Guide

Chippewa Valley Electric Cooperative Member Agreement

Interruptible Service – Water Heater

This agreement made and executed this _____ day of _____ 20____,
by and between Chippewa Valley Electric Cooperative, headquartered in Cornell, Wisconsin (hereinafter referred to as the "Cooperative"), and _____ (hereinafter referred to as the "member").

It is agreed by and between the parties as follows:

The Cooperative shall furnish and install all control devices which shall remain the property of the Cooperative. The Member shall permit the Cooperative and its agents and employees to enter upon premises for purpose of installing, maintaining, relocating, repairing, replacing and removing said devices and appurtenances thereto. The Cooperative shall have the authority to interrupt service taken under the selected Interruptible Rate Schedule, recognizing that the Cooperative may modify the terms and conditions of the selected Interruptible Rate Schedule from time to time as required by its load characteristics.

If the Cooperative determines or suspects that electric energy usage has not been consistent with this Agreement, Interruptible Rate Schedule, service rules or specifications, all control devices may be removed and all electric service billed under the general rate schedule. Only active, monthly billed, residential accounts, where the control device is installed, and **using at least 500 kilowatt hours per month, may qualify for the monthly \$3.00 credit.**

The Cooperative shall not be liable for any economic loss or personal discomfort due to the operation of the control device or the period of the service interruption.

Problems occurring with controlled loads shall be analyzed and corrected by an electrician. The member shall immediately notify the Cooperative if the control device is not functioning. The Cooperative will reimburse the homeowner or electrician for reasonable costs, only if the problem was with the control device.

If the control device is removed by the Cooperative and the interruptible rate discontinued for any reason, twelve months shall elapse before the control device and interruptible rate can be used by the Member again. This Agreement shall be in effect upon the date it was executed until cancelled by either party at any time after one year from the date of this contract, for any reason.

This Agreement shall be binding and inure to the benefit of the successors, legal representatives and assigns of the respective parties.

By: Chippewa Valley Electric Cooperative Signed By: _____
(Cooperative) (Owner Signature)

Number of Water Heaters _____ Size _____ Location Number _____
(heater must be 50 gallon or larger)

Daytime Telephone Number _____ Billing Number _____

Address _____ Member Number _____

Best Day of Week to Install Control _____ Notes: _____

Best Time of Day to Install Control _____

Sign & Return

Chippewa Valley Electric Cooperative

Dual Fuel & Load Management Wiring Guide

Chippewa Valley Electric Cooperative Member Agreement Interruptible Service - Air Conditioner

This agreement made and executed this _____ day of _____ 20____,
by and between Chippewa Valley Electric Cooperative, headquartered in Cornell, Wisconsin (hereinafter referred to as the "Cooperative"), and _____ (hereinafter referred to as the "member").

It is agreed by and between the parties as follows:

The Cooperative shall furnish and install all control devices which shall remain the property of the Cooperative. The Member shall permit the Cooperative and its agents and employees to enter upon premises for purpose of installing, maintaining, relocating, repairing, replacing and removing said devices and appurtenances thereto. The Cooperative shall have the authority to interrupt service taken under the selected Air Conditioner Interruptible Schedule, recognizing that the Cooperative may modify the terms and conditions of the selected Interruptible Schedule from time to time as required by its load characteristics.

All central air conditioning units at account must be controlled.

If the Cooperative determines or suspects that electric energy usage has not been consistent with this Agreement, Interruptible Schedule, service rules or specifications, all control devices may be removed and all electric service billed under the general rate schedule. Only active, monthly billed, residential accounts, where the control device is installed will qualify.

The Cooperative shall not be liable for any economic loss or personal discomfort due to the operation of the control device or the period of the service interruption.

Problems occurring with controlled loads shall be analyzed and corrected by an electrician. The member shall immediately notify the Cooperative if the control device is not functioning. The Cooperative will reimburse the homeowner or electrician for reasonable costs, only if the problem was with the control device.

If the control device is removed by the Cooperative and the interruptible rate discontinued for any reason, twelve months shall elapse before the control device and interruptible rate can be used by the Member again. This Agreement shall be in effect upon the date it was executed until cancelled by either party at any time after two years from the date of this contract, for any reason.

This Agreement shall be binding and inure to the benefit of the successors, legal representatives and assigns of the respective parties.

By: Chippewa Valley Electric Cooperative Signed By: _____
(Cooperative) (Owner Signature)
Air Conditioner Size _____ Location Number _____

Daytime Telephone Number _____ Billing Number _____

Address _____ Member Number _____

Best Day of Week to Install Control _____ Notes: _____

Best Time of Day to Install Control _____

Sign & Return

Chippewa Valley Electric Cooperative

Dual Fuel & Load Management Wiring Guide

Wiring Affidavit

Electrical Contractor Must Complete & Return this Form **(Must be Notarized)**

AFFIDAVIT

County of _____

State of Wisconsin

Meter #: 1-_____

WIREMAN'S NAME _____

WIREMAN'S ADDRESS _____

Being first duly sworn, on oath says he has completed the following wiring for electricity and that it is now ready for connection:

TYPE OF SERVICE (Check appropriate boxes)

RESIDENCE

OVERHEAD

CT SUB

EQUIPOTENTIAL PLANE

FARM

UNDERGROUND

SUB METER

COMMERCIAL

ELECTRIC HEAT

PARALLEL

ELECTRONIC GROUNDING

NO. OF PHASES _____ VOLTAGE _____ ENTRANCE SIZE _____

OWNER OF PREMISES

CUSTOMER'S NAME

LOCATION OF PREMISES TOWNSHIP _____ RANGE _____ SECTION _____
STREET _____ CITY _____

On the above described premises and in doing said wiring he complied with the provisions of the Wisconsin State Electrical Code, and that this affidavit is made pursuant to and in compliance with the provisions of Section 101.865 of the Wisconsin Statutes.

SIGNATURE OF WIREMAN _____

Subscribed and sworn to before me this _____ day of _____, 20____

NOTARY PUBLIC _____ COUNTY, WISCONSIN

COMMISSION EXPIRES _____

Before electricity can be furnished, this card, signed by the wireman before a notary public, must be returned to the utility.

TEAR OFF BEFORE MAILING

The department of commerce has adopted the National Electrical Code with certain deletion, changes, and additions which are found in Comm. 16, Wisconsin State Electrical Code. Copies of Comm. 16, Wisconsin State Electrical Code may be ordered from the Wisconsin Department of Administration, State Document Sales, PO Box 7840, Madison, WI 53707. See Comm. 16, WI Adm. Code, for availability information for the National Electrical Code.

SECTION 101.865 WISCONSIN STATUTES

Comm. 16.66 Connection of electric service: Pursuant to s. 101.865, Stats., the company or utility furnishing electric current shall obtain proof that electrical wiring complies with this chapter before furnishing the service, as follows:

- (1) CERTIFICATE REQUIRED. The electrical wiring required to be inspected may not be connected for use until a certificate is filed with the company or utility furnishing electric current. The certified inspector authorized to perform the inspection shall complete and file the certificate with the company or utility.
- (2) STATEMENT REQUIRED. Electrical wiring not requiring a certificate under sub. (1) may not be connected for use until a written statement is filed with the company or utility furnishing electric current indicating that the electrical wiring complies with this chapter. The electrical contractor or other person doing the wiring shall complete and file the written statement with the company or utility.

History: Cr. Register, September 1999, No. 525, eff. 10-1-99

Sign & Return

Chippewa Valley Electric Cooperative

Dual Fuel & Load Management Wiring Guide

CT Meter & Load Management Control Wiring Diagram

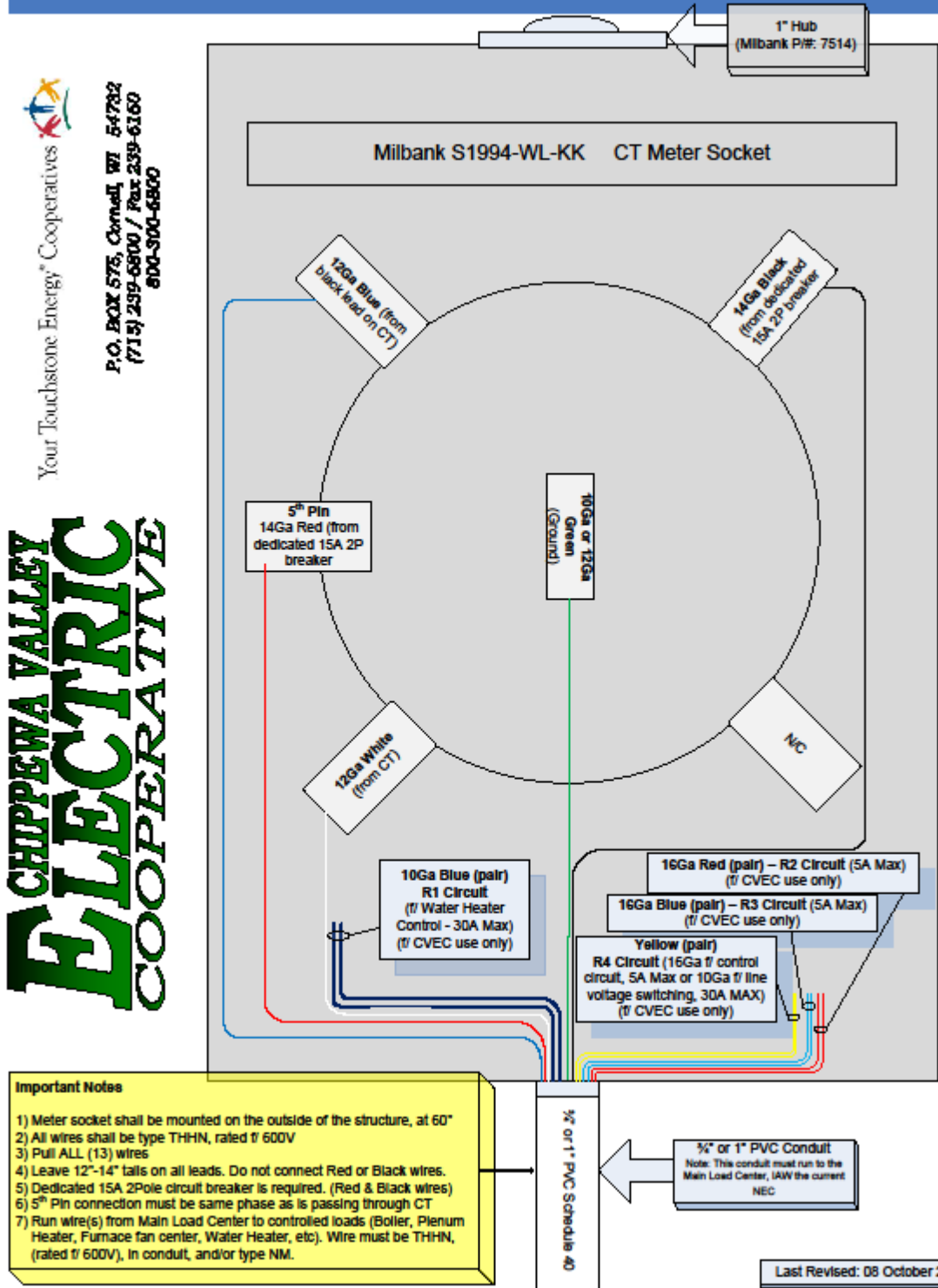

Your Touchstone Energy Cooperatives

CHIPPEWA VALLEY ELECTRIC COOPERATIVE

P.O. BOX 575, Cornell, WI 54732
(715) 239-6800 / Fax: 239-6160
800-300-6800

Chippewa Valley Electric Cooperative

Dual Fuel & Load Management Wiring Guide

DF Meter.vsd

1 CT



Your Touchstone Energy[®] Cooperatives



P.O. BOX 575, Cornell, WI 54732
(715) 239-6800 / Fax 239-6160
800-300-6800

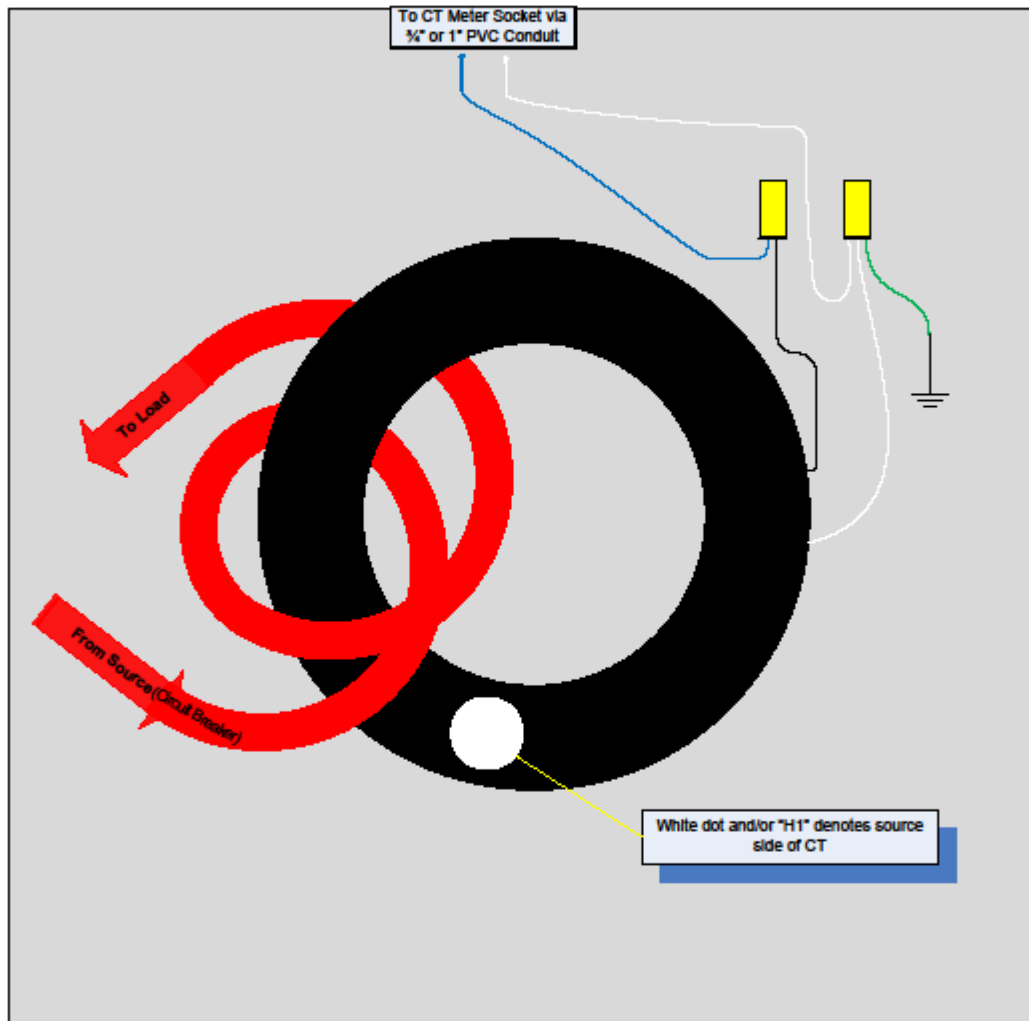

Notes

- 1) Each 240V load must have one leg pass through the CT with one complete wrap as shown
- 2) All loads passing through the CT must be on the same phase, and pass through in the same direction
- 3) 120V loads, if authorized by CVEC, pass through CT only once

CT Wiring

Last Revised: 08 October 2008

Chippewa Valley Electric Cooperative

Dual Fuel & Load Management Wiring Guide



Your Touchstone Energy[®] Cooperatives 

P.O. BOX 575, Cornell, WI 54732
(715) 239-6800 / Fax 239-6160
800-300-6800

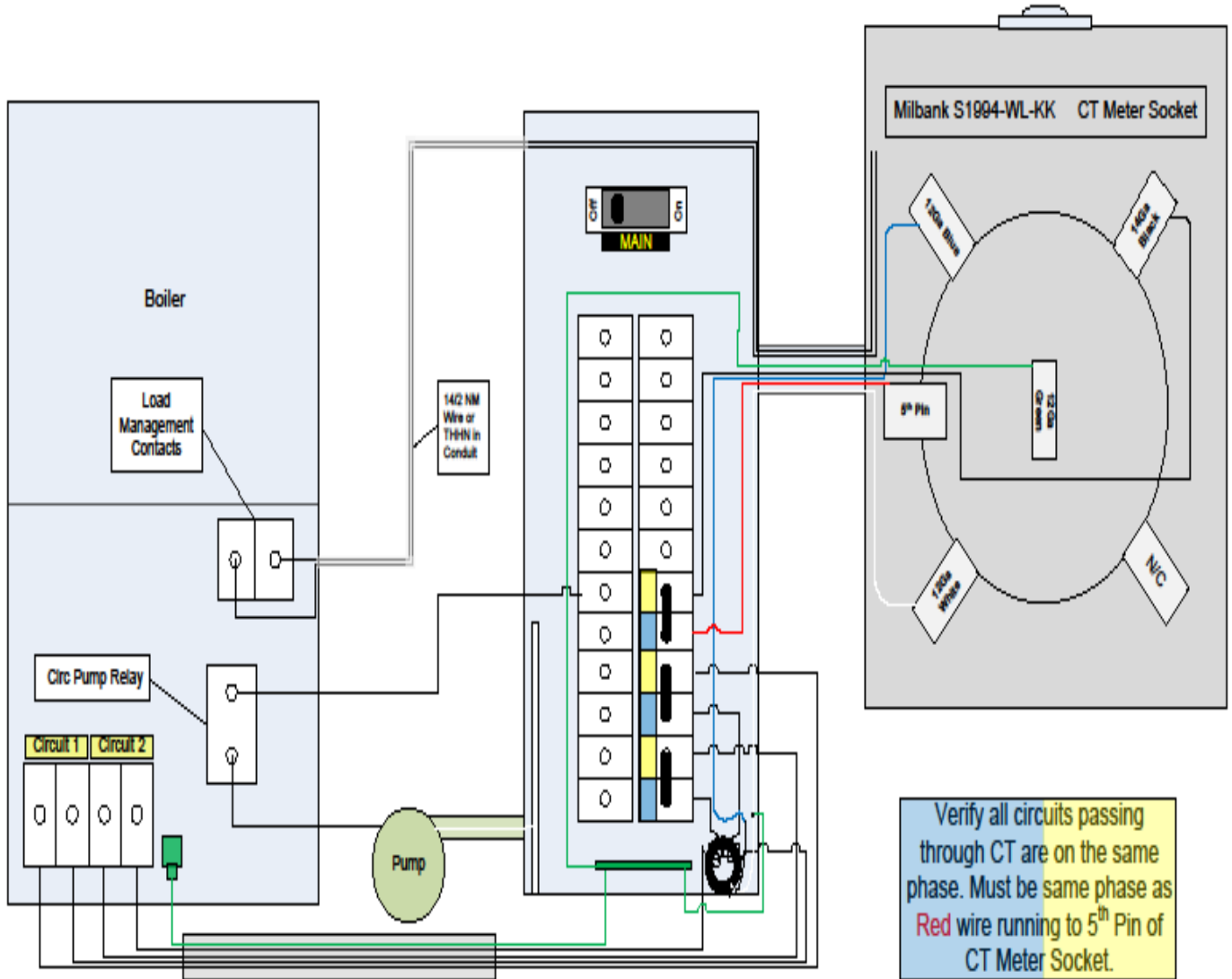

Typical Boiler Installation w/ CT Meter Socket

Last Revised: 12 December 2007

Parallel Meter & Double Pedestal Load Management Control Wiring Diagram

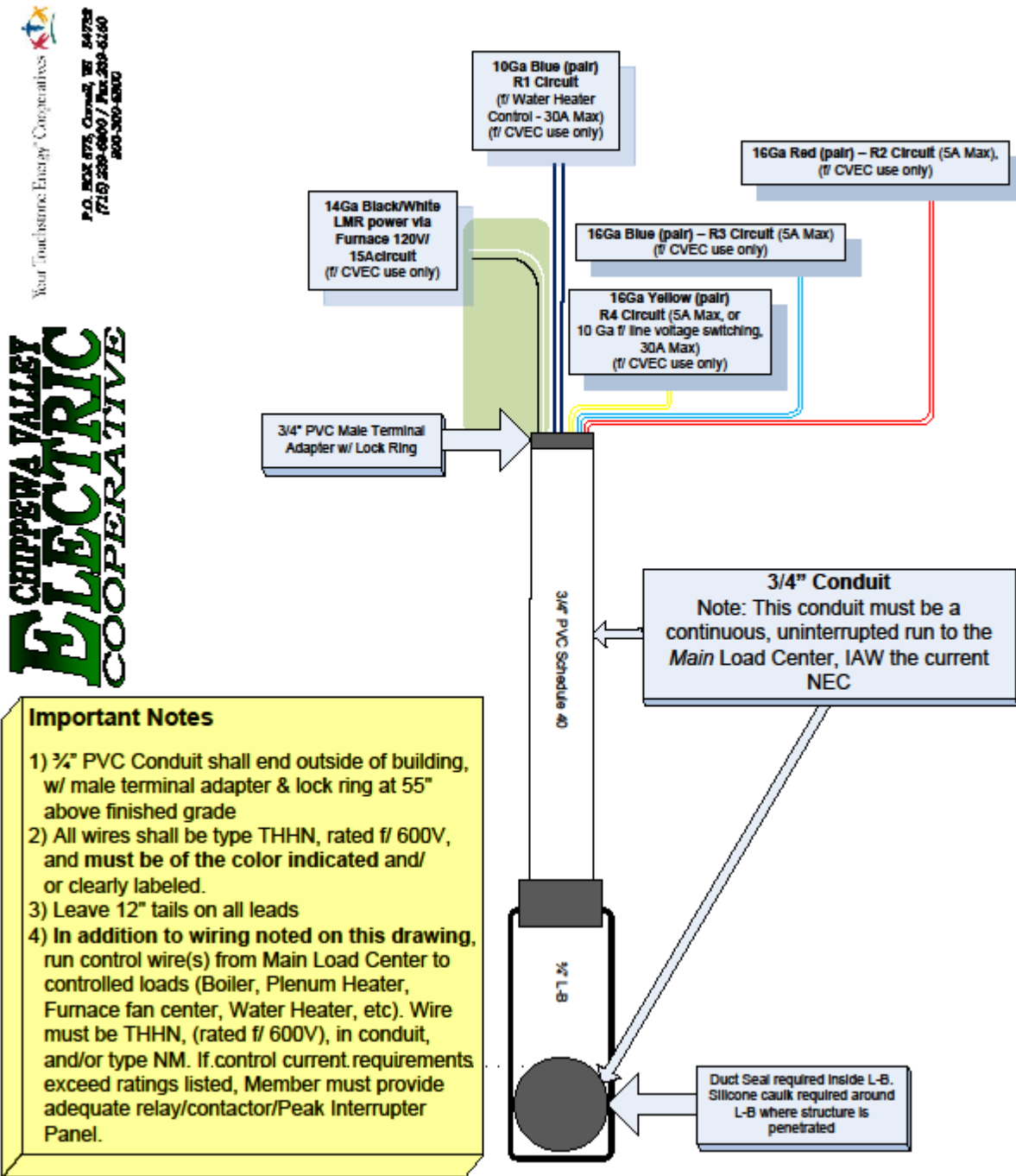

Your Touchstone Energy Cooperatives
P.O. BOX 8775, Grand, IA 54758
(715) 239-6669 / Fax 239-6250
800-500-5000

CHIPPewa VALLEY
ELECTRIC
COOPERATIVE

- Important Notes**
- 1) 3/4" PVC Conduit shall end outside of building, w/ male terminal adapter & lock ring at 55" above finished grade
 - 2) All wires shall be type THHN, rated f/ 600V, and must be of the color indicated and/ or clearly labeled.
 - 3) Leave 12" tails on all leads
 - 4) In addition to wiring noted on this drawing, run control wire(s) from Main Load Center to controlled loads (Boiler, Plenum Heater, Furnace fan center, Water Heater, etc). Wire must be THHN, (rated f/ 600V), in conduit, and/or type NM. If control current requirements exceed ratings listed, Member must provide adequate relay/contactors/Peak Interrupter Panel.

Last Revised: 25 May 2010